

Floor Drills

400FD(X)M Series

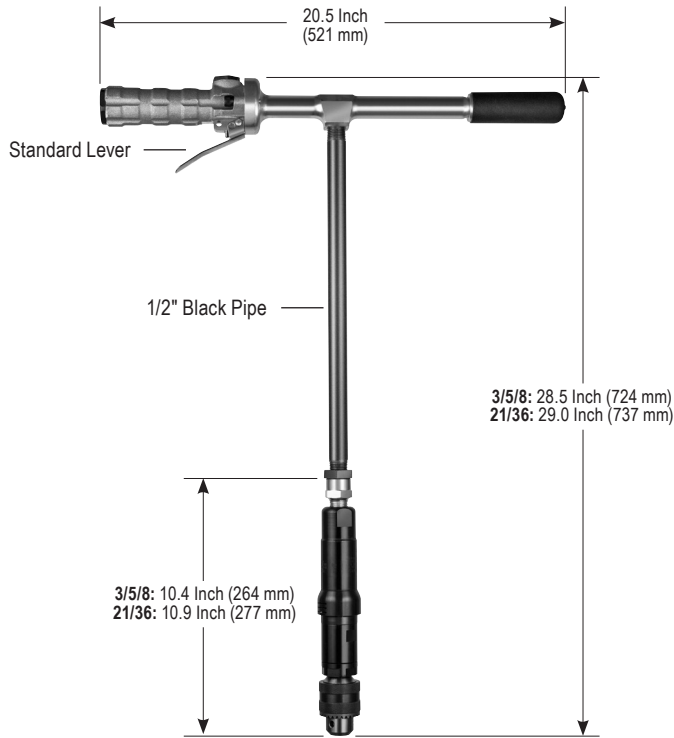

400FD3ML;5500;D1/2;P15

517FD1M Series

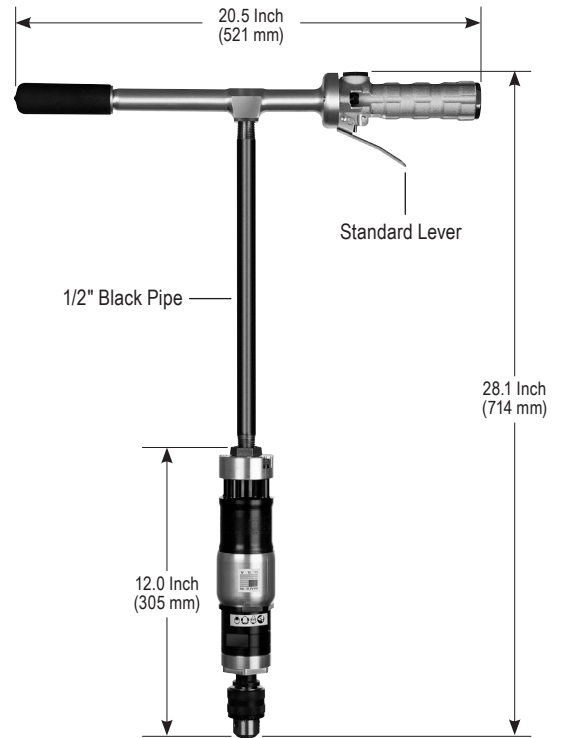

517FD1ML;4000;D1/2;P15

Output	Gear Ratio / Rated Speed	Lever Style	MODEL NUMBER	Output	Gear Ratio / Rated Speed	MODEL NUMBER
1/2" (13 mm) Drill Chuck	3:1 / 5500 RPM	Standard Lever	400FD3M;5500;D1/2;P15	1/2" (13 mm) Drill Chuck	4:1 / 4000 RPM	517FD1ML;4000;D1/2;P15
		Safety Lever	400FD3MK;5500;D1/2;P15			
	5:1 / 4000 RPM	Standard Lever	400FD5M;4000;D1/2;P15			
		Safety Lever	400FD5MK;4000;D1/2;P15			
	8:1 / 2500 RPM	Standard Lever	400FD8M;2500;D1/2;P15			
		Safety Lever	400FD8MK;2500;D1/2;P15			
	21:1 / 900 RPM	Standard Lever	400FD21M;900;D1/2;P15			
		Safety Lever	400FD21MK;900;D1/2;P15			
	36:1 / 550 RPM	Standard Lever	400FD36M;550;D1/2;P15			
		Safety Lever	400FD36MK;550;D1/2;P15			

HP 1.2 H.P. (900 W)

Lbs 3/5/8: 8.3 Lbs. (3.8 Kg)
21/36: 8.5 Lbs (3.8 Kg)

cfm 35 cfm (16.5 L/s) Max

SUPPLY 1/2" NPT Inlet
3/8" (10mm) Hose Size

HP 1.5 H.P. (1125 W)

Lbs 10.8 Lbs (4.9 Kg)

cfm 35 cfm (16.5 L/s) Max

SUPPLY 1/2" NPT Inlet
1/2" (13mm) Hose Size

STANDARD EQUIPMENT

- Tool
- Operating Instructions and Service Manual